

# Basic Technical Fundamentals of Builders Hardware Exit Devices

**SARGENT**<sup>®</sup>  
**ASSA ABLOY**



# Table of Contents

	Page
SARGENT History .....	1
What is an Exit Device? .....	2
Preface – History of Exit Devices.....	3
Doors – (A Brief Review) .....	4
Doors – Single Doors, Pairs of Doors .....	5
History of the Federal Specifications and ANSI/BHMA Standards. . .	6, 7
Exit Devices in General.....	8
Rim Exit Device .....	9
Mortise Lock Exit Device.....	10
Surface Vertical Rod Exit Device .....	11
Mechanical Function .....	12
Outside Trim .....	12
Some Abbreviations Used in the Builders Hardware Field .....	13



## Preface

Ever since people have felt the desire to protect hearth, home and family, they have used locks to protect what is theirs.

There are probably more lock mechanisms in the world than any other mechanical device. You have probably used various types of locks ever since you were a child, without really thinking about them – but how much do you know about these products from a technical perspective?

Over the last 150 years, many industry terms, products, functions and specifications have been created for hardware applied to doors, but what are they and how are they used?

This booklet covers only the fundamentals of the most basic products that SARGENT manufactures. Using this basic knowledge, you can build on your expertise by using product catalogs and other related publications.

## Specifications

In the mid 1850's, SARGENT and Company moved from New Britain to New Haven, Connecticut and began to grow in size. By the late 1800's, the SARGENT catalog exceeded 800 pages and offered a broad array of products. The line included virtually every product a small hardware store might need to fill its shelves. What SARGENT didn't manufacture itself was bought, packaged and resold to meet the hardware stores' needs. The products listed in the late 1800's catalog ranged from cow bells and cake turners to kitchen food choppers, screws, coal shovels, "C" clamps, carpenter squares, animal traps, mop handles, such window and door hardware as hinges and sash fasteners and door locks of many variations. The list of products sold under the SARGENT name at the turn of the century goes on and on. Because the company's product line was so vast, the SARGENT name became known in homes, on farms and in businesses throughout the country. But as the company evolved, it began to

specialize in its more profitable and mechanically complicated products – namely, locks and door closers. Throughout the early to mid-1900's, SARGENT pared down its line and introduced its first exit devices, a focus which has intensified in recent years.

The products that SARGENT chose to specialize in - door locks, door closers and exit devices – have made the company a well-recognized supplier of BUILDERS HARDWARE. This term applies to a large group of products used for purposes of protection, security and convenience, as distinguished from heavier and/or simpler materials used in construction such as columns, beams, nails, screws, etc.

SARGENT chose to specialize in high-quality BUILDERS HARDWARE, but also has a small line of lower-end, value-priced products designed for residential hardware or small building use.

## What is an Exit Device?



### The basic purpose of an exit device is to save lives

An exit device – sometimes called a Fire Exit Bolt, an Exit Bolt or a Crash Bar – is a mechanical lock operated from the inside of an outward swing door through the use of a crossbar or push rail extending at least halfway across the width of the door. An exit device must always release the door, allowing exit without prior knowledge of operation. Any horizontal force on the cross bar or push rail will release the door.

In any building area or room where many people may be gathered, safe and easy egress must always be possible. The number of doors that should be equipped with exit devices is determined by building codes. The doors in these areas must always swing out in the direction of people exiting the building in case of emergency.

The doors must always be free to operate from the inside of the area, yet they may be locked to prevent access from the outside.

## **Preface**

### **History of Exit Devices**

*In the year 1903, 596 people lost their lives in a theater fire in Chicago.*

*In the year 1908, 174 children died in a school fire in Cleveland.*

*In the year 1911, 148 girls perished when fire swept through a shirt factory in New York.*

*In the year 1942, 492 lives were lost in the Coconut Grove nightclub fire in Boston.*

*In the year 1946, 61 people died in the LaSalle Hotel fire in Chicago.*

These horrifying figures represent only some of the massive loss of life due to fire in the first half of the 20th century. In many of these cases, scores of people were crushed to death in the panic that resulted as people frantically tried to get out of buildings. Sometimes there were not enough doors, sometimes doors were locked and sometimes doors that opened inward were blocked shut because of a surge of people.

In the 1911 shirt factory fire, the owner and operator of the building was arrested, put on trial and convicted for not providing adequate protection for his employees. He was heavily fined and sent to prison. His defense was that there were no laws defining the degree of protection he had to provide for his workers, but he was found guilty nonetheless.

As a result of these tragedies, the National Fire Protection Association (NFPA) was created in the early 1900's. Insurance companies played a big part in its development. For the first few years of its existence, the NFPA committee on fire doors, which was made up of experts in the fire protection field, devoted its energies to analyzing specific causes of death in a number of major fires. As a result, the first exit device was developed in 1911 and the first building standards that required improved safety measures were published. The list of standards has multiplied over the years and continues to be refined today.

# Basic Technical Fundamentals of Builders Hardware Exit Devices



## Doors – (A Brief Review)

Before we start discussing door closers, we would like to share some facts about what they are used on and with – namely, DOORS. Doors may seem simple, but their use and construction is a whole field by itself. Therefore, this booklet will discuss only the fundamentals you need to know.

Most doors are made of wood or steel. (Doors made of aluminum or glass are also available but are not as common). Wood doors may be made of solid wood or laminate. Steel doors are usually made from formed sheet steel and reinforced

with steel plates to add strength and allow the attachment of hinges and other hardware.

The most common thickness of a swinging door is 1-3/4" thick and 36" wide. Doors may be flush or constructed with panels made of glass, metal or wood. These panels are usually placed below the face of the door.

*Here are some examples of door variations that you should be aware of...*

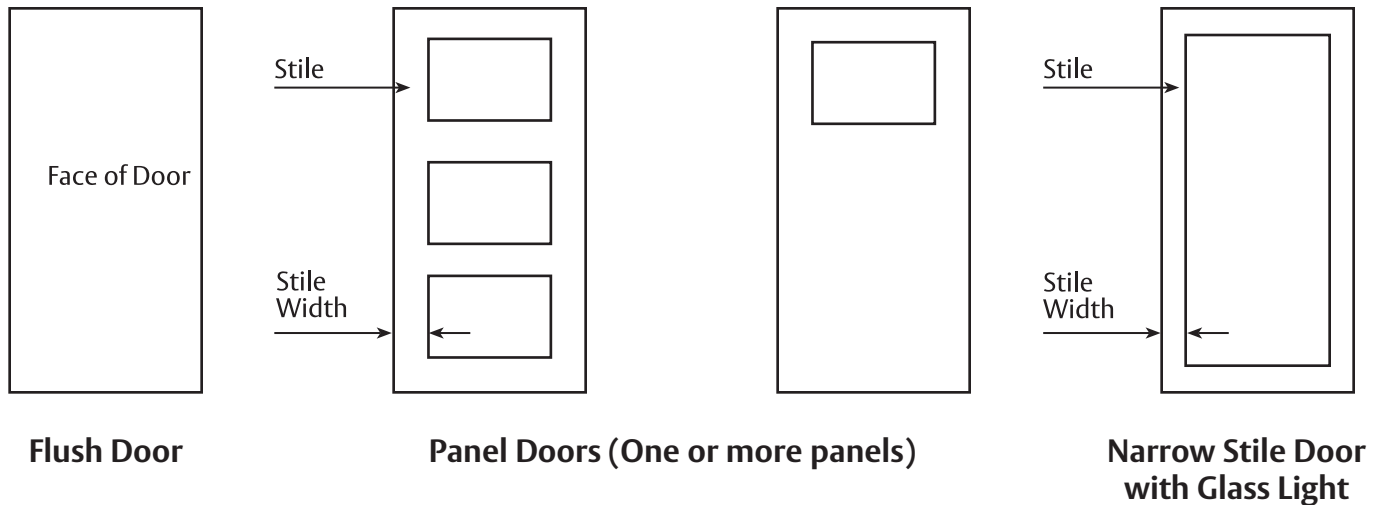

Most doors are used to allow privacy, restrict sound, improve security and control effects of the weather. Another form of door is called a "Fire Door." A fire door is made and constructed of materials that are noncombustible, within limits. A fire door can be a type of wood door treated with a fire-resistant substance that will help contain a low-temperature fire.

Fire doors may also be made of steel. These are constructed to withstand much higher degrees of heat caused by fires. They are sometimes lined with a material to reduce the exchange of heat from one side of the door to the other.

Doors sold as "Fire Doors" have passed certain fire tests conducted by an independent laboratory. This type of door is usually called a "Labeled Fire Door," as the classification listing is shown on the door itself. Hardware used on these doors is also tested and required to meet certain standards.

An exit door is sometimes referred to as a fire exit door, which does not necessarily mean it is a labeled fire door. Whether a labeled fire door should be used depends upon where it will go. (This subject is a study in itself and is not covered in this booklet).

# Basic Technical Fundamentals of Builders Hardware Exit Devices

**Doors** – Single Doors, Pairs of Doors with and without Mullion, Hands of Doors. Other options are Sliding Doors, Overhead Doors, etc.

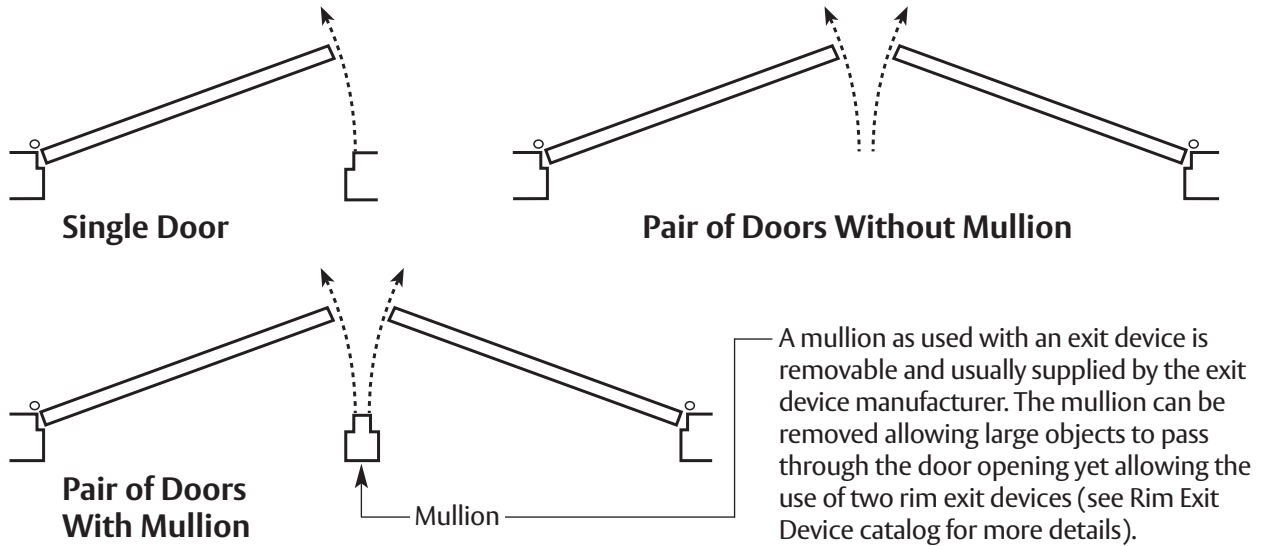

## Hands of Doors

While there are a few exceptions, doors when fabricated are usually handed. The hands of doors are referred to as follows:

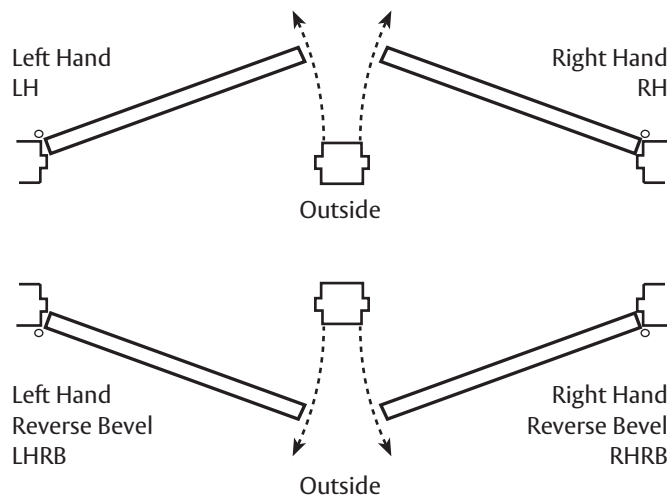

The term 'outside' in the illustration not only is used to indicate the outside of a building, but more importantly, to indicate the side of a door which can be locked requiring a key or other means to gain entry.

**Note:** Exit Devices are always used on the reverse bevel doors.

**History of the Federal Specifications and ANSI/BHMA Standards**  
**Definition of Terms used in text below**

**Federal Specifications** – (U.S. Specifications) for builders hardware were developed and issued by the U.S. General Services Administration of the Federal Supply Services.

**ANSI** – (American National Standards Institute) – An organization that has a system for setting standards prepared and submitted by a second party.

**BHMA** – An organization of the Builders Hardware Manufacturers.

**ANSI/BHMA** – Standards are found in a publication prepared by BHMA and approved and published by ANSI.

Although the Federal Specifications for Builders Hardware, i.e. locks, door closers, exit devices, etc., are no longer published, they are discussed here because a few of the terms and references are still used. A little history on this may prove useful.

The United States Government was and probably still is the largest buyer and user of Builders Hardware. The chief purpose of the Federal Specifications was to standardize purchasing requirements for items that are regularly used by two or more departments of the Federal Government.

The Federal Specification for Locks and Door Trim, including exit devices, was number FF-H00106 and was first published in 1933. Prior to that date, there were no Builders Hardware Standards. As a result, each lock manufacturer had its own door lock cutout dimensions, its own finish description and so forth. (Note: Finish symbol or description, as discussed here, refers to the decorative finish of a doorknob, door plates, etc.) Before the federal government established finish designations, most hardware manufacturers just used their own.

Examples of finish designations used by various hardware manufacturers before the establishment of U.S. standards are as follows:

<b>Hardware Manufacturer</b>	<b>Dull Chrome</b>	<b>Dull Bronze</b>
YALE	626	612
SARGENT	26D	10
CORBIN RUSSWIN	626	612
McKINNEY	CD	DE

Copyright © 2002-2009, Sargent Manufacturing Company, an ASSA ABLOY Group company. All rights reserved.  
Reproduction in whole or in part without the express written permission of Sargent Manufacturing Company is prohibited.

# Basic Technical Fundamentals of Builders Hardware Exit Devices

Ironically, U.S. finish designations had nothing to do with the base material of the finished part. For example, the federal government established US26D for dull chrome and US10 for dull bronze. Even though the federal specifications are obsolete, the use of the designations the government established is still common today. The industry is slowly adopting its own ANSI/BHMA finish numbers, which also defines the base material.

## Example:

US Finish	Descriptions	ANSI/BHMA
US3	Polished brass, clear coated	605
US4	Satin brass, clear coated	606
U59	Polished bronze, clear coated	611
US10	Satin bronze, clear coated	612
US10B	Oxidized bronze, oil rubbed	613
US10BL	Oxidized satin, bronze, clear coated	—
US20D	Statuary dark bronze, clear coated	—
U526	Polished chrome	625
US26D	Satin chrome	626

**Note:** Lacking an industry standard prior to the establishment of ANSI/BHMA, the industry adopted federal specifications for its own use even when products were not being sold to the U.S. government.  
In the current ANSI/BHMA specifications for mortise and bored locks, the Federal Specification numbers for door cutouts are currently used. There is no carry-over from the Federal Specifications for exit devices, with the exception of U.S. finishes such as U.S. 10.

The Federal Specification program for Builders Hardware first started to come to an end in 1963. In the fall of that year, BHMA members met with an executive of Federal Supply Services, which was in charge of preparing Federal Specifications for Builders Hardware. A Federal Supply Service Department official pointed out that his department had no one trained in the Builders Hardware field. He suggested that BHMA should consider writing its own standards. He further pointed out that if a known standards organization was used which canvassed for approval of various individuals and agencies, the Federal Government would accept the standards prepared by BHMA. The American National Standards Institute (ANSI) met these requirements, and so BHMA picked ANSI as the canvasser and publisher of BHMA standards, known today as the ANSI/BHMA standards.

## Exit Devices in General

This booklet covers only the fundamentals of Exit Devices manufactured by SARGENT. Using this basic knowledge, you can build on your expertise by using product catalogs and other related publications.

The below illustrations show the three most common types of exit devices.

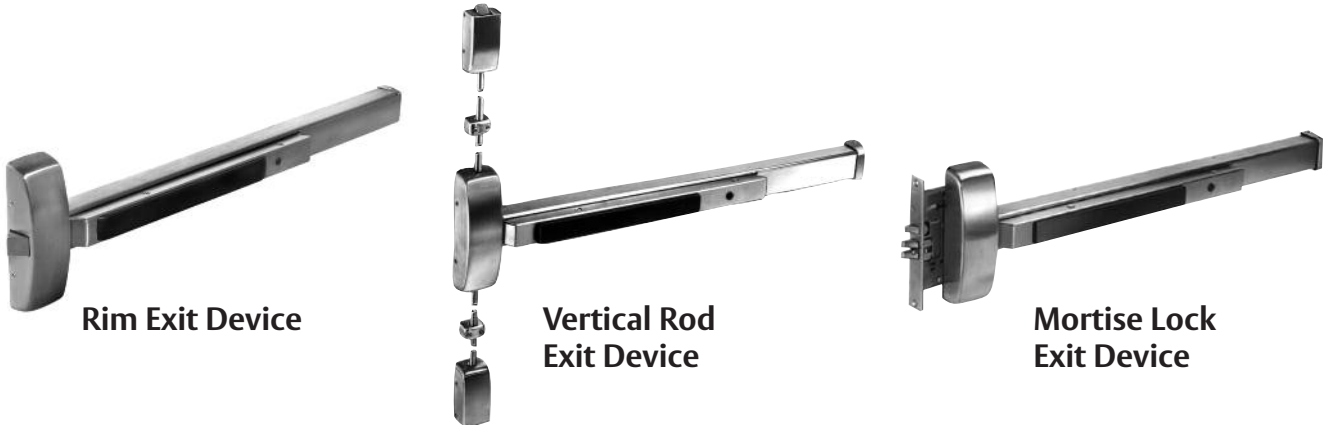

## Exit devices are divided into two categories, namely, “Panic” and “Fire Exit Hardware.”

1. A “panic” exit device is one which always allows fast and easy exit with no knowledge of the operation needed.

In high frequency use doors, the actuating bar may be locked in the depressed position through the use of an Allen wrench type key, a mechanical cylinder key or an electrical method. The locking down of the actuating bar is referred to as dogging.

Dogging the actuating bar down during periods of high frequency accomplishes a few objectives.

1. Converts door to a push/pull type of operation.
2. Reduces operation noise.
3. Reduces wear on the exit device.

**Note:** There are designs of fire exit hardware in which the actuating bar may be dogged down electrically and released when the electrical power is cut off through the use of a fire detection system but this feature is not discussed in this booklet.

2. “Fire Exit Hardware” (F.E.H.) is a panic exit device designed in such a way that it is suitable for use on a fire-rated door. The actuating bar does not have a dogging feature. The latch bolts must always be operative. The latch bolts must be able to hold the door closed at temperatures reaching up to 1800°F, for a period of three hours.

# Basic Technical Fundamentals of Builders Hardware Exit Devices

## Rim Exit Device

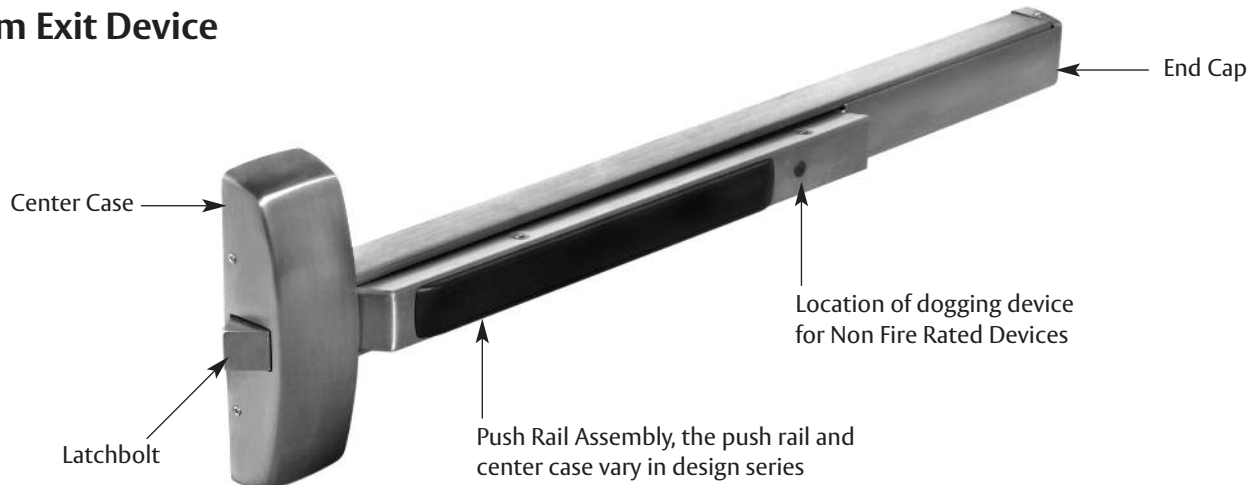

A “Rim Exit Device” is an exit device applied to the surface of the door. This makes the application very simple. The latch bolt projects from the center case. This device is well suited to a single door or pairs of doors with a removable mullion, as shown below.

The strike shown in the illustration below is surface-applied. While this is the most common strike for rim exit devices, there are others available for various reasons. (Consult product catalog.)

### Single Door

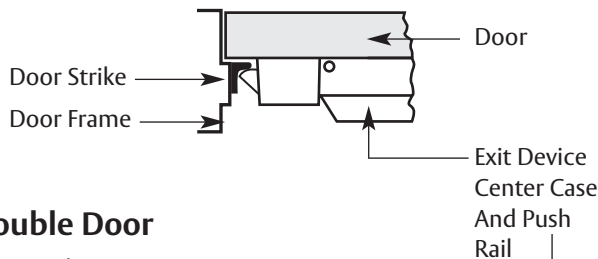

### Double Door

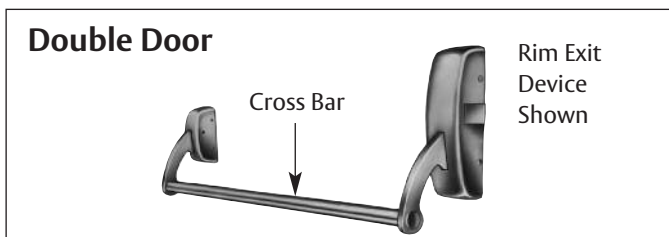
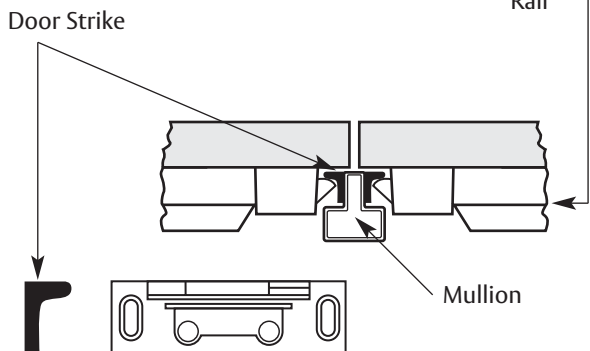

### Removable Mullion

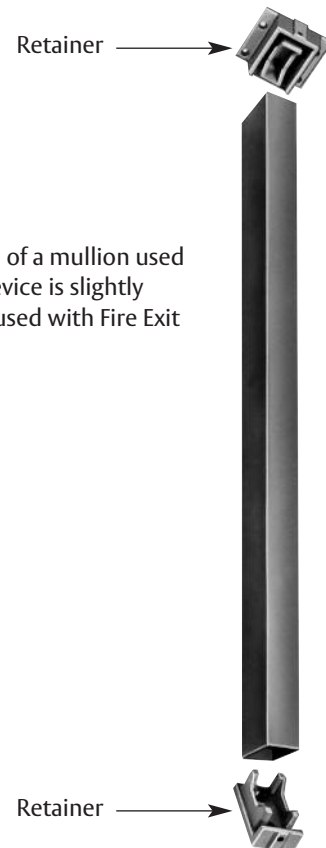

**Note:** The shape of a mullion used with a Panic Exit Device is slightly different than one used with Fire Exit Hardware.

**Mortise Lock Exit Device**

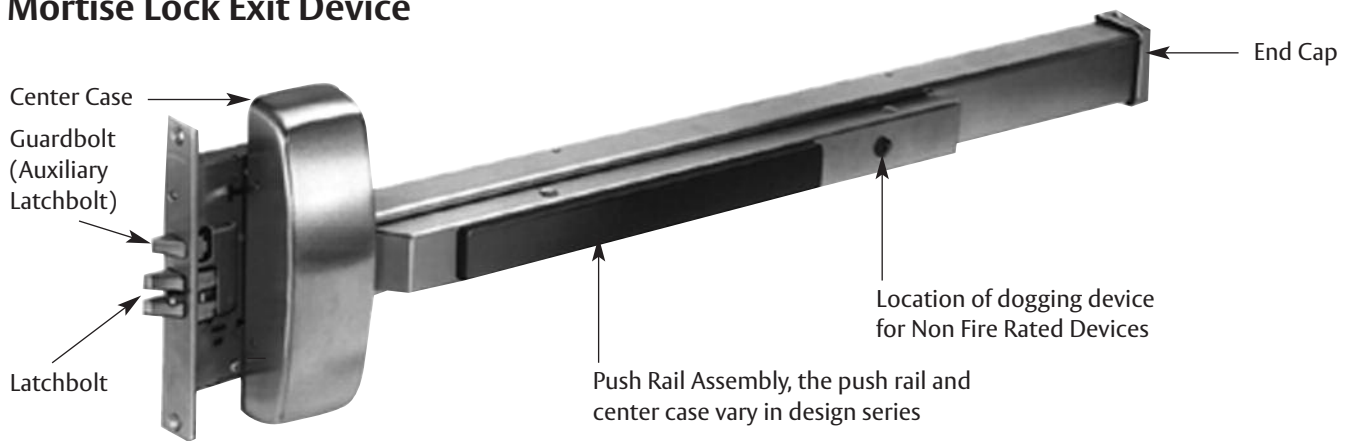

A "Mortise Lock Exit Device" can be used on a single door but is normally used on the active leaf of a pair of doors. The inactive leaf of the pair of doors is usually equipped with a vertical rod exit device.

In this double door combination, an open-back strike is primarily used, as illustrated below. This allows each door to operate independently, allowing an unobstructed double door opening when desired.

The latch bolt is spring-loaded, allowing the latch to be depressed while the door is being closed. The latch bolt then enters the strike, holding the door in the closed position.

The guard bolt is also depressed when the door is closed. However, when the latch bolt enters the strike, the guard bolt will remain depressed. The guard bolt will lie against the strike face causing the latch bolt to become fixed in the projected position. This feature prevents the latch bolt from being depressed through the use of a credit card or some other tool that would allow unauthorized entry.

The guard bolt (auxiliary latchbolt) in the mortise lock is a necessity. The space between the door and the frame or the opening between the two doors in a pair makes the latch bolt accessible from the outside. A person could gain entry by prodding the latch bolt back into the mortise lock.

**Note:** There are ways of closing up the opening between the door and the frame or the space between two doors in a pair of doors, but these procedures are not discussed in this booklet.

**Single Door**

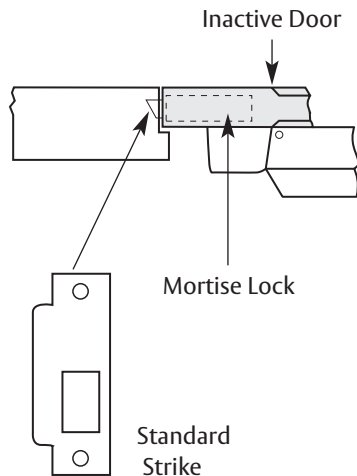

**Pair of Doors**

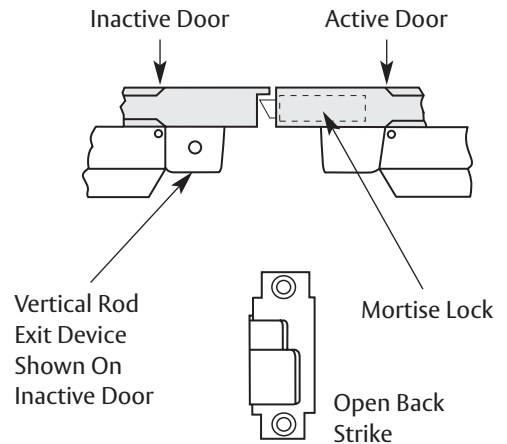

Copyright © 2002-2009, Sargent Manufacturing Company, an ASSA ABLOY Group company. All rights reserved. Reproduction in whole or in part without the express written permission of Sargent Manufacturing Company is prohibited.

**Surface Vertical Rod Exit Device**

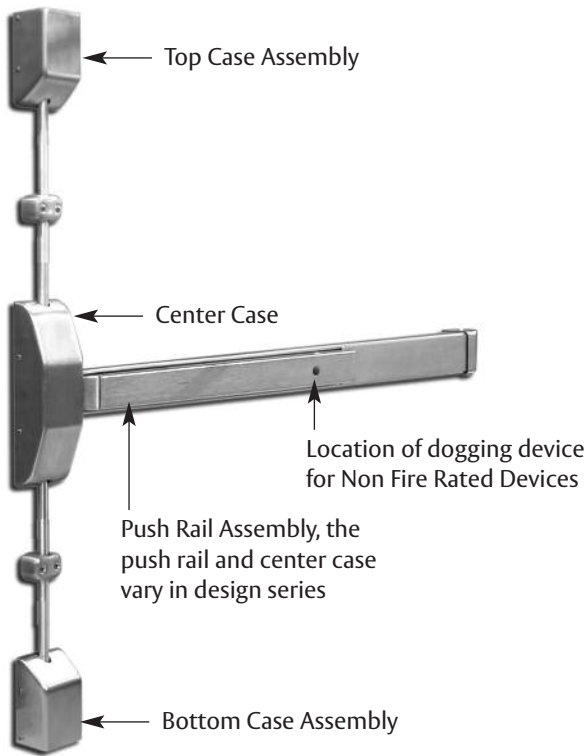

Also available where the vertical rods are concealed within the door



A “Surface” (or concealed) Vertical Rod Exit Device is normally used on the inactive leaf of a pair of doors. The active door would have a mortise lock type exit device on it. Two doors or a pair of doors cannot be locked to each other. One door - called the inactive leaf - must be locked to the door frame. A mortise

lock exit device, used with a vertical rod exit device on a pair of doors, allows a full double-door opening. (Two rim-type exit devices used with a removable mullion cause the mullion to obstruct the full opening, unless it is removed.)

**Note:** The application of two vertical rod exits on a pair of doors or a rim exit device on the active door and a vertical rod exit device on the inactive leaf is rare and makes special strikes and door coordinators necessary. The applications are not discussed in this booklet.

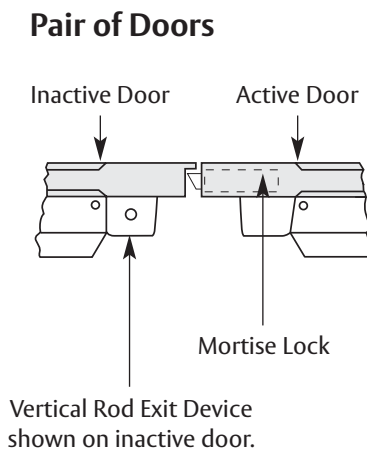

**Strikes – Top and Bottom**

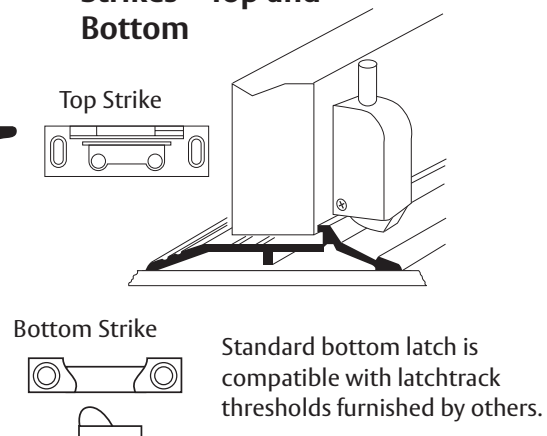

**Mechanical Function**

When a person wishes to open a door with an exit device mounted on the inside, the locking mechanism is released by a horizontal push on the crossbar or push rail from the inside.

Methods of entering the locked door from the outside are numerous and vary in the various exit device lines. These various

methods are called mechanical functions and are given numbers for identification.

Some of the mechanical functions are listed below. For other mechanical functions, consult the Exit Device catalog.

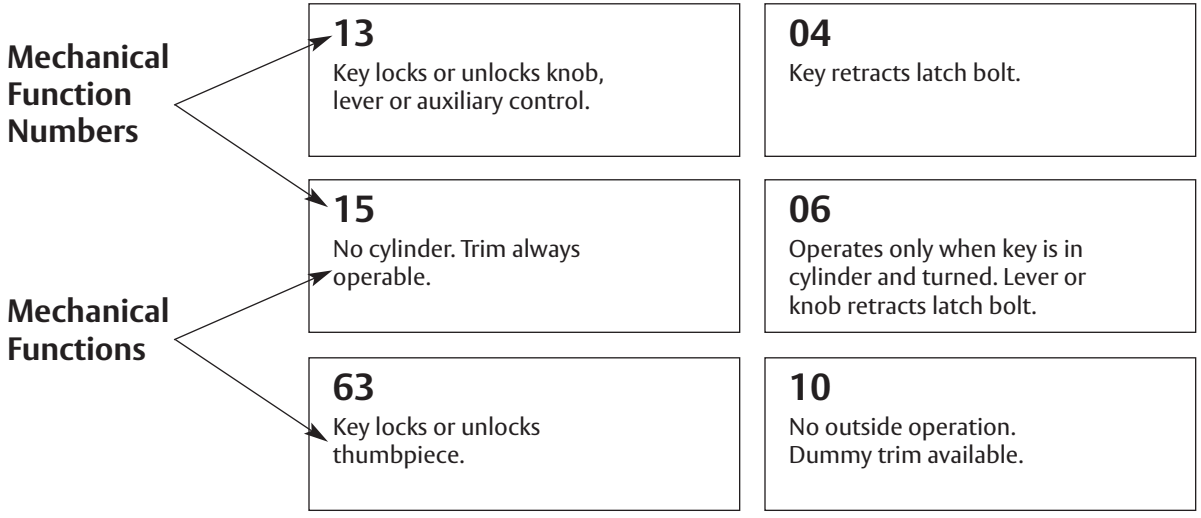

**Outside Trim**

The term “Outside Trim,” when used in discussing exit devices, refers to the hardware on the outside of the door in which an exit device is applied to the inside surface of the door.

Typical outside trims are shown below. Consult the Exit Device catalog for more detail referring to the many designs.



Copyright © 2002-2009, Sargent Manufacturing Company, an ASSA ABLOY Group company. All rights reserved. Reproduction in whole or in part without the express written permission of Sargent Manufacturing Company is prohibited.

## **Some Abbreviations Used in the Builders Hardware Field**

### **1. Associations Involved in Building Codes**

- NFPA** - National Fire Protection Association
- UBC** - Uniform Building Code
- BOCA** - Building Officials and Code Administrators
- SBCC** - Southern Building Code Conference

### **2. Testing Laboratories – (Door and Hardware field)**

- UL** - Underwriters Laboratories
- ULC** - Underwriters Laboratories of Canada
- WHI** - Wernock Hersey, Inc.

### **3. Doors and Hardware Association**

- DHI** - Door and Hardware Institute
- AHC** - Architectural Hardware Consultant

### **4. Miscellaneous**

- ADA** - Americans with Disabilities Act

SARGENT Manufacturing Company  
100 Sargent Drive  
New Haven, CT 06511 USA  
800-727-5477 • [www.sargentlock.com](http://www.sargentlock.com)

Founded in the early 1800s, SARGENT<sup>®</sup> is a market leader in locksets, cylinders, door closers, exit devices, electro-mechanical products and access control systems for new construction, renovation, and replacement applications. The company's customer base includes commercial construction, institutional, and industrial markets.

Copyright © 2002, 2009, Sargent Manufacturing Company, an ASSA ABLOY Group company. All rights reserved. Reproduction in whole or in part without the express written permission of Sargent Manufacturing Company is prohibited.

ASSA ABLOY is the global leader in door opening solutions, dedicated to satisfying end-user needs for security, safety and convenience.